

**PETITE
FRITURE**
ÉDITEUR DE DESIGNS

COLLECTION

01 | 2017

Furniture, lighting, accessories



PETITE FRITURE

**PETITE
FRITURE**
ÉDITEUR DE DESIGN

PETITE FRITURE is an *Éditeur de designS*, founded in 2009 and run by Amelie du Passage. Through its original collaborations with designers coming from various fields **PETITE FRITURE** thrives on the need to give new life to **products, places** and **moments** that are beautiful, light and delicate. All of this is tempered with the same spirit and created with the same demanding levels of results.

At **PETITE FRITURE** we have a taste for emerging and audacious creation that bypasses frontiers and arouses emotion.
And a conviction: **creation has no worth unless it is shared.**

In order for you to discover the talents that we are so passionate about, **PETITE FRITURE** invites you into a surprising experience with the will to make you smile.

**PETITE FRITURE.
Make Good Things Happen.**

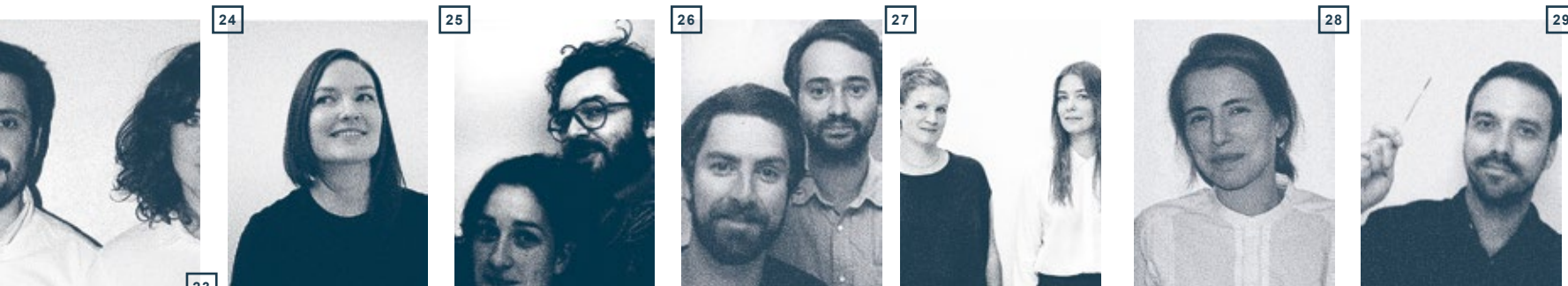
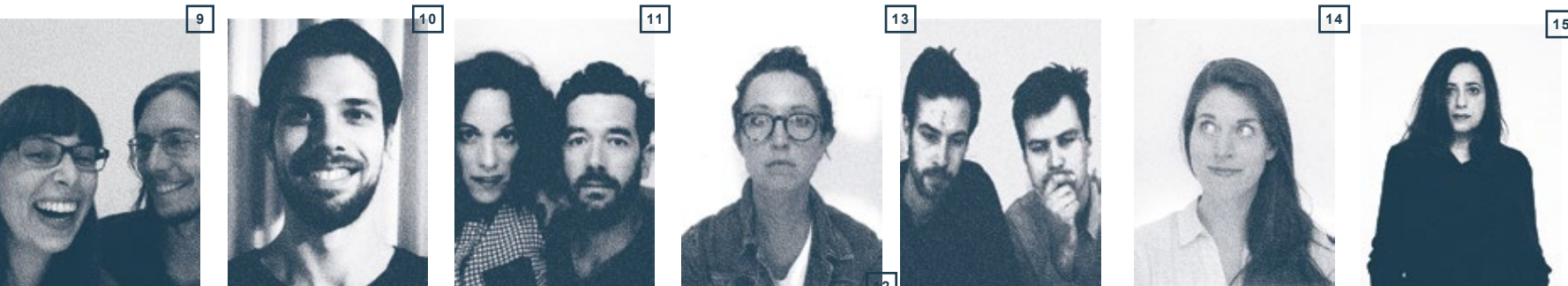
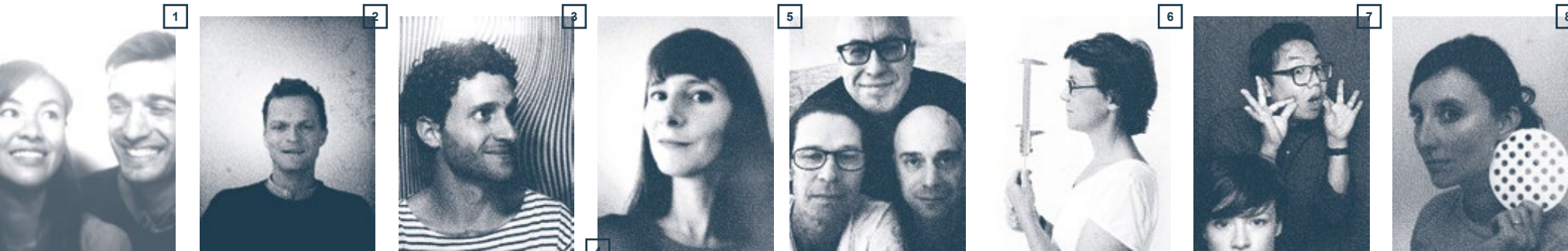

- 01 — Amandine Chhor & Aïssa Logerot
- 02 — Andreas Engesvik
- 03 — Arthur Leitner
- 04 — Céline Frébault
- 05 — Claesson Koivisto Rune
(Ola Rune, Eero Koivisto, Marten Claesson)
- 06 — Constance Guisset
- 07 — Daniel • Emma
(Daniel To, Emma Aiston)
- 08 — Elise Fouin
- 09 — Färg & Blanche
(Fredrik Färg, Emma Marga Blanche)
- 10 — Federico Floriani
- 11 — Gaëlle Gabillet & Stéphane Villard
- 12 — Giorgia Zanellato
- 13 — Goliath Dyèvre & Quentin Vaultot
- 14 — Hanna Emelie Ernsting
- 15 — India Mahdavi
- 16 — Jean-Charles Amey
- 17 — Marc Sarrazin
- 18 — Morten & Jonas
(Morten Skjærpe Knarrum, Jonas Norheim)
- 19 — Noé Duchaufour - Lawrance
- 20 — Pierre Favresse
- 21 — POOL
(Léa Padovani, Sébastien Kieffer)
- 22 — Sam Baron
- 23 — SCMP DESIGN OFFICE
(Sébastien Cluzel, Morgane Pluchon)
- 24 — Shelley Steer
- 25 — Studio BrichetZiegler
(Caroline Ziegler, Pierre Brichet)
- 26 — Studio Nocc
(Jean-Christophe Orthlieb, Juan Pablo Naranjo)
- 27 — studio vit
(Helena Jonasson, Veronica Dagnert)
- 28 — Tiphaine de Bodman
- 29 — Tomas Kral

COLLECTION

01 | 2017

Furniture, lighting, accessories





AURA
TOMAS KRAL

AURA is a pendant lamp in a rolled metal sheet which plays with light in the same way as a delicate lace veil.

+ MARKET – Noé Duchaufour - Lawrance – see p.29 / 44

NARCISO
ECAL / GIORGIA ZANELLATO

Draw attention to the role of flowers by using NARCISO and its mirrored stainless steel.



FRANCIS
CONSTANCE GUISET

Coming from experiences with pigments diluted in water, FRANCIS is an echo of an ageing mirror with its bright oxidation.



MINERA
STUDIO NOCC

The MINERA water jug is inspired by a smooth pebble on which crystals have aggregated, the water flows on the uneven side like a small stream.



GRID POOL

In 2015 POOL signed the GRID daybed, referring to the Bauhaus style and honouring the graphical talents of the duo.

In 2016 POOL develop the concept and bring GRID in an all too modular system, by creating basic modules: simple armchairs, corner armchairs, stool, and coffee table join the range with the two seats sofa. They can all be attached by simple fixations in order to create many configurations: 3 seats sofa, corner sofa, confident... to suit any envy.





CAST
studio vit

CAST is a duo of lights, a game of geometry and of materials where the sphere in glass and the concrete hemisphere create a dialogue.



HOFF
MORTEN & JONAS



HOFF created by designers duo Morten & Jonas is a collection of two modular stools and two modular armchairs. They enable to compose a sofa as an entire living room area. Its main characteristic is the visual and tactile qualities of surfaces. Morten & Jonas work with objects that they hope make people feel something.

LOOP
AMANDINE CHHOR

A poetic shelf with beautiful curves inspired by constraints of industrial production of trolley.





ÉTOILE
CLAESSON KOIVISTO RUNE

This chopping board is above all about geometry, when a carved pattern becomes more than an ornament and embodies a function.



PETSTOOLS
HANNA EMELIE ERNSTING

PETSTOOLS are not only stools, but delightfully playful and cosy companions.



ANT
SAM BARON

An ant prisoner of a glass sphere tells us a story: when the invisible becomes visible.

PANACHE
CONSTANCE GUISET

PANACHE, adorned with its colored tassels, is a mirror with mischievous elegance and exacerbated forms.



VOLUTES
TIPHAIN DE BODMAN

Signed by Tiphaine de Bodman, VOLUTES is a new pattern declined in wallpapers as well as cushions. It evokes movements and vibrations. VOLUTES is a twirling brush stroke that evokes the fields of wheat of Van Gogh and the meadows of Max Liebermann.

+ VOLUTES cushion
Tiphaine de Bodman – see p.45



GRANDISSANT
JEAN-CHARLES AMEY

Thought as an organic candleholder, GRANDISSANT alludes to the image of trees structure, and invites us to change its shape to our ideal.



WILD THINGS
PIERRE FAVRESSE

This container gives a fantastic sensorial experience hidden under the shape of an innocent but strange and wild animal.



JUNGLE
TIPHAINE DE BODMAN

The JUNGLE wallpaper, signed by Tiphaine de Bodman, brings your home to life in an exotic atmosphere. The JUNGLE pattern exists also declined in cushions.



+ JUNGLE cushion
Tiphaine de Bodman – see p.45



NUBILO
CONSTANCE GUISET

NUBILO is a dreamlike destination, where the soft and round cushions can be easily arranged to ensure your comfort.

+ BASIL – Arthur Leitner – see p.26 - 27

VARIATIONS
TIPHAINE DE BODMAN

From distilled water to a cluster of dots, this wallpaper will have your head in the clouds.

BASIL
ARTHUR LEITNER

With an aerial structure that plays with the density of the geometrical tabletop, BASIL tables were born from the wish to use cork's natural qualities.

+ WILD THINGS – Pierre Favresse – see p.23





LANTERNA
SAM BARON

From a simple lamp to a recollection of Chinese rounded lantern, the pendant lamp LANTERNA with its golden heart is a tribute to light.

SO-SAGE
SAM BARON

Sam Baron signs SO-SAGE, pendant lamps in evocative forms of “sausages” in moulded blown borosilicate glass. Each is unique.

+ MARKET – Noé Duhaufour - Lawrance – see p.10 / 44

SUCCESSION
PETITE FRITURE x REVOL
FÄRG & BLANCHE

The organic and contemporary aesthetic of the collection SUCCESSION is born from the spirit of experimentation of Färg & Blanche and the exacting standards of savoir-faire of the REVOL artisans, the historic manufacturer of French porcelain.





CURIOSITY
SAM BARON

With a humorous reference to hunting trophies, CURIOSITY make a surprising hop in your interior.





**ISO - A & ISO - B
POOL**

With its strong graphism, ISO plays
with perspectives and volumes.



PARROT
INDIA MAHDAVI

An orange-red foot combined with a colorful and geometric tabletop, bring to life chatty tables.



CHERRY
DANIEL • EMMA

Head over heels or cherry on the bottom, with the new CHERRY pendant lamps the designers, from Daniel • Emma studio, enhance light with the irised cherry and its conical hat.



MASK
FEDERICO FLORIANI

Like a painted mask over a shaman's face, the graphic lines of the mirrors give a good twist to your reflection.

BUBBLE
VAULOT & DYÈVRE

Popped out straight from Vaulot & Dyèvre's imagination, the BUBBLE coat pegs are like soap bubbles frozen and solidly fixed forever.



BAMBOU
CÉLINE FRÉBAULT

Inspired by nature, the salt and pepper set is like two transparent branches set on the table.



MOIRE
MARC SARRAZIN

Thought of as a garment, the moiré effect of the textile sublimates the atmosphere by creating a diffused light.

WILD CAR
PIERRE FAVRESSE

The organic scaly form of this moneybox evokes a universe that is at once familiar yet remote.



OBJETS 2822
GAËLLE GABILLET &
STÉPHANE VILLARD

These black glass decanters invite you to create your own products or use refillable products.



VERTIGO
CONSTANCE GUISET

Movement, illusion, lightness, surprise...
VERTIGO reduces space to an intimate atmosphere and comes to life when draughts make it slightly lose its balance.



DOTS
SHELLEY STEER



The DOTS pattern was created through the exploration of the form and action of expressing dots with graphite. Pressure and placement combine to create a leaf motif, which is then layered and put into a repeating pattern. The DOTS pattern is declined in wallpapers and cushions.



MARKET
NOÉ DUCHAUFOR - LAWRENCE

MARKET is a range of tables that is inspired by the wooden lattices that form market stalls. Its simple design makes it easy to match with our everyday interior.

+ TRAME – Amandine Chhor & Aïssa Logerot – see p.46

MINERALS
SHELLEY STEER

The MINERALS pattern was designed taking inspiration from naturally occurring minerals and rocks. Colour, form and surface markings were interrupted and altered to create a unique surface design. The MINERALS pattern is declined in wallpapers and cushions.



MÉDITERRANÉA
NOÉ DUCHAUFOR - LAWRENCE

Inspired by the weightlessness “of laundry billowing in Mediterranean balconies” MÉDITERRANÉA is an elegant series of light: a cloth of brass with a perforated graphic motif, resting on a light structure, which sculpts and diffuses the LED light.

+ VOLUTES cushion – Tiphaine de Bodman
+ JUNGLE cushion – Tiphaine de Bodman
+ DOTS cushion – Shelley Steer

TRAME
AMANDINE CHHOR &
AÏSSA LOGEROT

Two main tracks come in a curve together to create this comfortable armchair.

+ VERTIGO – Constance Guisset – see p.43





CANDLE TORCH
ANDREAS ENGESVIK

With its protective shape CANDLE TORCH gives the flame a powerful glow and a magical touch.



TIDELIGHT
PIERRE FAVRESSE

Hand blown in a mould, TIDELIGHT's texture and shape increase light's diffusion and striped glow.



OUTDOOR

HOLLO
AMANDINE CHHOR & AÏSSA LOGEROT

The HOLLO tables and stool are a tribute to industrial codes with a shape that gives priority to use and function.



GRILLO
ELISE FOUIN

The wall lamp GRILLO is a simple perforated circle that diffracts and dims light like a solar eclipse. GRILLO exists in two versions: the wall lamp with a simple electrical point connected directly to the wall, and the wall lamp embellished by a colored cable (switch and plug) providing a great liberty to set up the lamp as it suits you.

+ BASIL – Arthur Leitner – see p.26 - 27



BRILLE
PETITE FRITURE

PETITE FRITURE transcribes on this old fashioned striped bowl in a universal language the French expression « Boire du petit lait ».

TUBERCULE
SCMP DESIGN OFFICE

Delicate and subtle printing in concrete created by SCMP Design office, TUBERCULE is a duo of coat pegs inspired by the organic forms of potatoes.

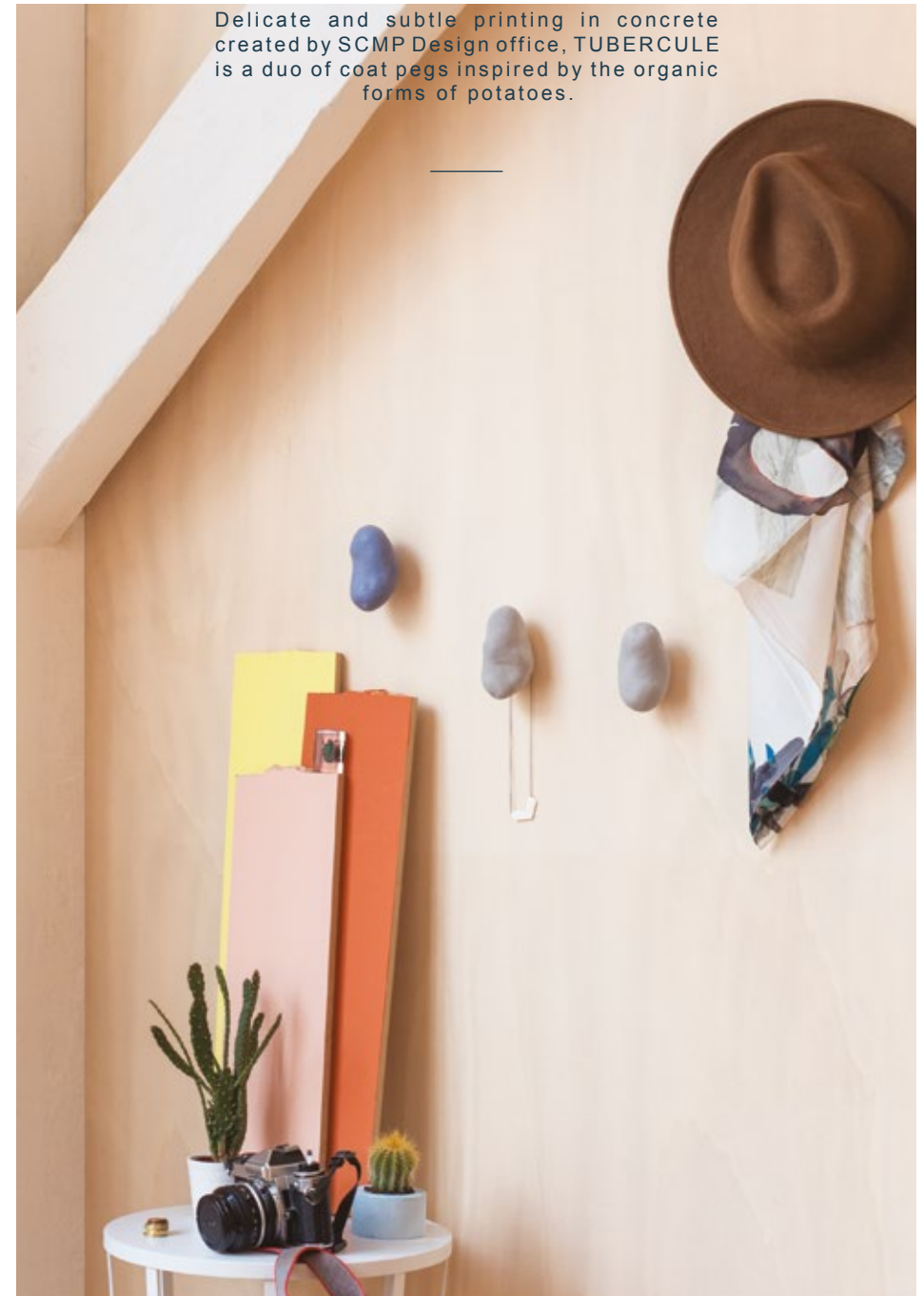

Glossary



IP ratings are the specifications or 'code' that grade the protection factor given to any light fitting against the touching of live parts (electrical) and protection against the access of solid items/bodies. In addition, the code specifies protection against the harmful ingress of liquids to the light fitting.

Each IP code, has two digits to define its level of protection.

- 1st digit : protection against the access of solid items/bodies (2=protection against the access of solid items > 12,5mm)
- 2nd digit : protection against the harmful ingress of liquids (0 = unprotected)



The CE mark indicates that a product meets the requirements of relevant EEC directives **EN 60 598-1** and **EN 60 598-1-2**. Its prime purpose is to facilitate its free trading and movement within the EEC. It's also a safety and quality proof.



Max power - CE marking :
Our lightings comply with the CE mark within the limits of suitable bulb.



The Glow Wire Test simulates thermal stresses which may be produced by such sources of heat or ignition. The test certifies that the tested product is non inflammable between 0° et the maximum indicated temperature.



Quantity of packages



Flat pack



Packed by...



Sold by...



Steel with high protection zinc treatment for outdoor use



Aluminium with anti-UV coating for outdoor use



High resistance



Assembly



Base bulb



U.K. Cable



Stackable



Microwave



Oven



Dish washer



Apply paste to the wall



Dry-peelable



Good lightfastness



Washable



Half drop match



Straight across match



No washing



Washable at 30°C



Dry cleaning



No drying



No spinning



Low temperature ironing

See p.46-47



TRAME

AMANDINE CHHOR & AÏSSA LOGEROT
CHAIR

*Coated steel, grained epoxy paint,
high protection zinc treatment*

Polyester

CHAIR

L: 53.5 cm; W: 44 cm; H: 76.5 cm (back); h: 43.5 cm (seat)
W: 8 kg

CUSHION

L: 41.5 cm; W: 33 cm; H: 2 cm
Colours : Medium grey / Black / White

Colours : Yellow / White / Grey / Black

Standards :

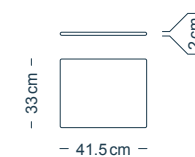
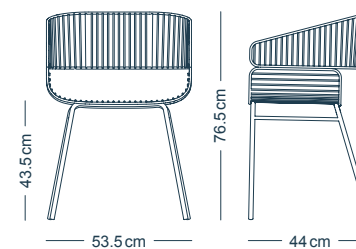

See p.50-51



HOLLO

AMANDINE CHHOR & AÏSSA LOGEROT
STOOL & TABLES

*Coated steel, grained epoxy paint,
high protection zinc treatment*

Colours : *Burgundy / Blue / Gold /
Anthracite / Black / White*

Standards :

TABLE FOR TWO

Ø: 50 cm; H: 72 cm
W: 7 kg

COFFEE TABLE

Ø: 70 cm; H: 33 cm
W: 12 kg

STOOL OR SIDE TABLE

Ø: 35 cm; H: 44 cm
W: 4 kg

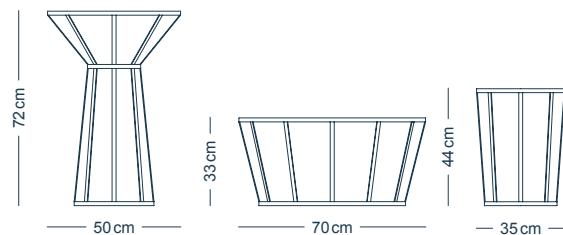

See p.26-27



BASIL

ARTHUR LEITNER
SIDE TABLES

*Cork, steel, grained epoxy paint, recycled rubber particles**

TRAPEZE

L: 49 cm; W: 49 cm; H: 46.5 cm
W: 6 kg

SPHERE

Ø: 47 cm; H: 46.5 cm
W: 6 kg

PYRAMID

L: 54 cm; W: 54 cm; H: 46.5 cm
W: 4 kg

Colours : *Black - Black flecked cork* /
White - Natural cork*

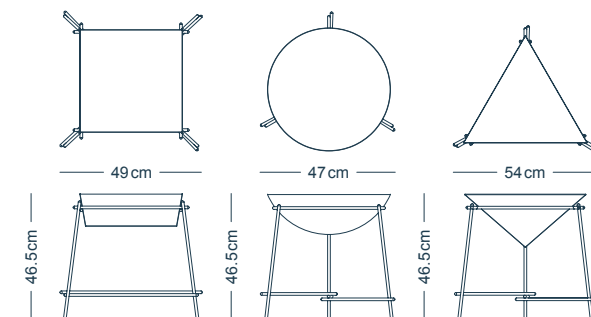

See p. 32-33

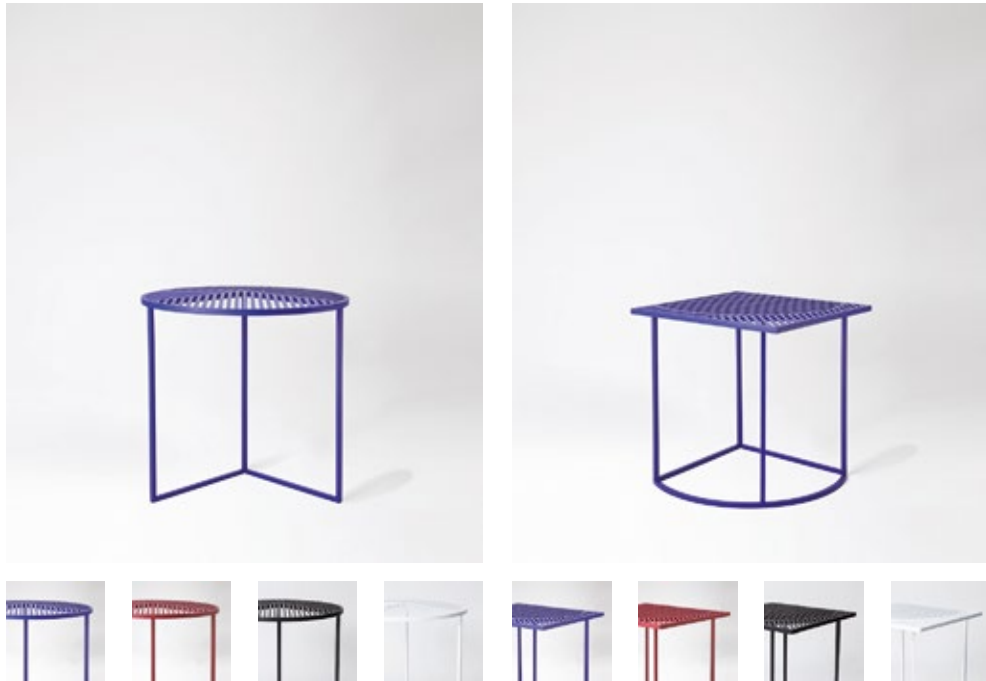

ISO-A & ISO-B
POOL
 (LÉA PADOVANI & SÉBASTIEN KIEFFER)
 SIDE TABLES

*Coated steel, grained epoxy paint,
 high protection zinc treatment*

ISO-A (ROUND)
 Ø: 47 cm; H: 45 cm
 W: 5 kg

ISO-B (SQUARE)
 L: 40 cm; W: 40 cm; H: 42.5 cm
 W: 5 kg

Colours : Blue / Burgundy / Black / White

Standards :

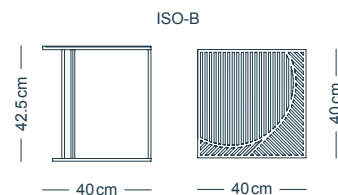
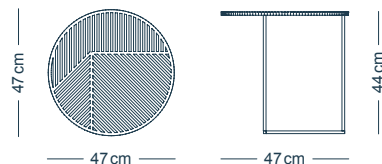

See p. 34



PARROT
INDIA MAHDAVI
 TABLES

*Enameled steel, coated steel, epoxy paint,
 high protection zinc treatment*

SMALL
 L: 90 cm; W: 90 cm; H: 73 cm
 W: 39 kg

Standards : x2

LARGE
 L: 200 cm; W: 90 cm; H: 73 cm
 W: 80 kg

Standards : x3

Colours : Light pink /
 Light yellow /
 Light turquoise /
 Cream - Pink pattern /
 Light green - Dark green pattern

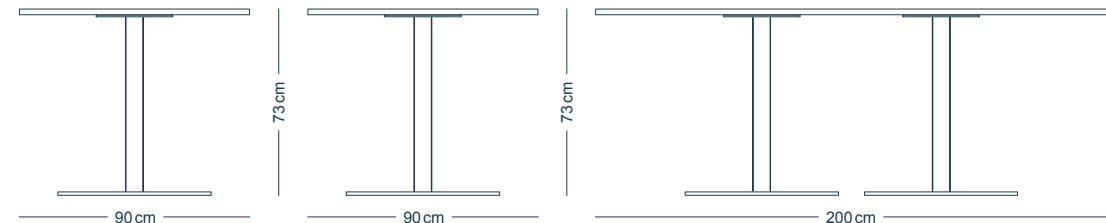

WEEK-END
STUDIO BRICHETZIEGLER
OUTDOOR CHAIRS & TABLES



Aluminium with anti-UV coating for outdoor use, grained epoxy mat paint



CHAIR

W: 52 cm; L: 50 cm; H: 77 cm (back); H: 45 cm (seat)
W: 5 kg

Standards :

PACKED BY 2	PACKED BY 4	SOLD BY 2	SOLD BY 4
-------------	-------------	-----------	-----------

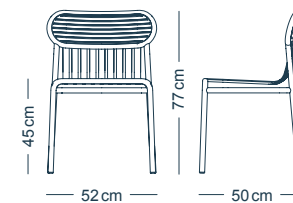

BRIDGE

W: 57 cm; L: 50 cm; H: 77 cm (back); H: 45 cm (seat);
H: 68 cm (armrests)
W: 5.5 kg

Standards :

PACKED BY 2	PACKED BY 4	SOLD BY 2	SOLD BY 4
-------------	-------------	-----------	-----------

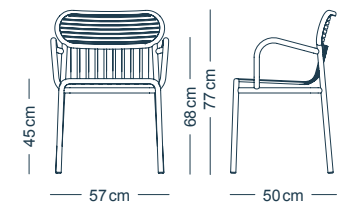

WEEK-END
STUDIO BRICHETZIEGLER
OUTDOOR CHAIRS & TABLES



ARMCHAIR

W: 66 cm; L: 62 cm; H: 77 cm (back); H: 40 cm (seat);
H: 62 cm (armrests)
W: 7.5 kg



COFFEE TABLE

Table top with welded slats
W: 60 cm; L: 69 cm; H: 32 cm
W: 5 kg

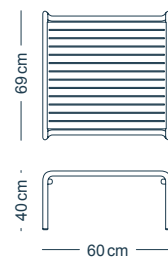
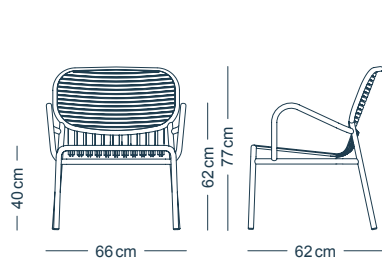

SQUARE TABLE

Table for 2-4 people / Cut-out and perforated table top in slats
W: 85 cm; L: 85 cm; H: 75 cm
W: 12 kg

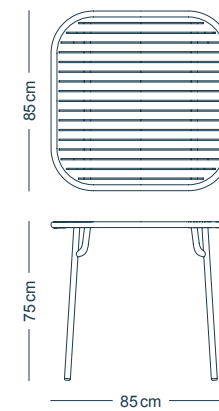

MEDIUM RECTANGULAR TABLE

Table for 6-8 people / Cut-out and perforated table top in slats
W: 85 cm; L: 180 cm; H: 75 cm
W: 22.5 kg

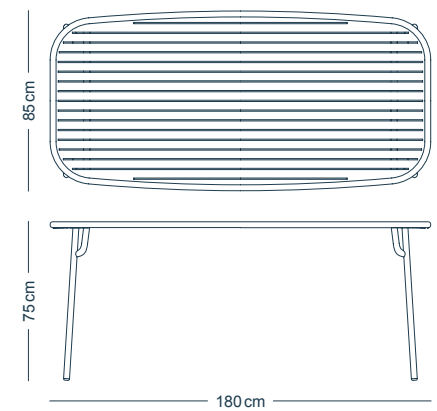

See p. 10/29/44



MARKET

NOÉ DUCHAUFOUR-LAWRANCE TABLES

Solid oak, waterproof recycled leather (only for the small rectangular table)

RECTANGULAR TABLE

SMALL /
L: 142 cm; W: 71 cm; H: 74 cm
W: 25 kg

LARGE /
L: 200 cm; W: 90 cm; H: 74 cm
W: 37 kg

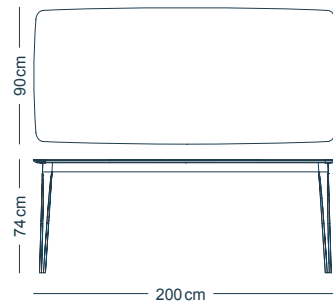
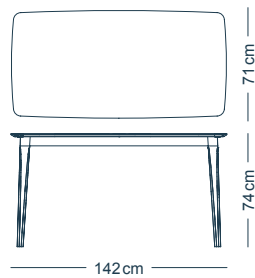

EXTENDING TABLE (2 LEAVES)

WITHOUT LEAF /
L: 180 cm; W: 90 cm; H: 74 cm

WITH 2 LEAVES /
L: 270 cm; W: 90 cm; H: 74 cm

WITH 1 LEAF /
L: 225 cm; W: 90 cm; H: 74 cm

W: 46 kg

Tabletop colours :
Oak / Leather (can only be associated
with the small rectangular table)

Standards : 

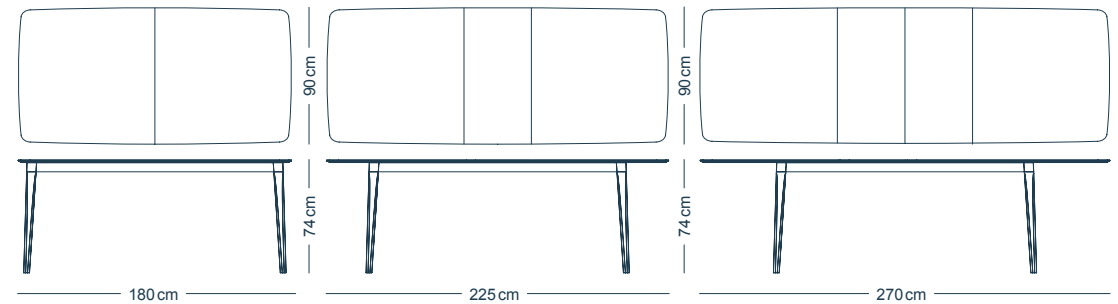

See p. 19



PETSTOOLS
HANNA EMELIE ERNSTING
STOOLS

Wool, nylon, polyester, wood, steel, foam

Ø: 48 cm; H: 60 cm; h: 35 cm (seat)

W: 3 kg

Colours : *Fin - Light grey /
Ella - Anthracite grey /
Daisy - Pink*

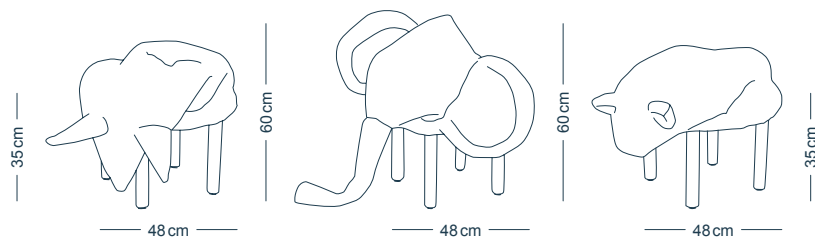

See p. 24-25



NUBILO
CONSTANCE GUISETT
ARMCHAIR / SOFA

Coated steel, wool, velvet, polyester foam

ARMCHAIR

L: 77 cm; W: 70 cm; H: 65 cm (back); h: 40 cm (seat)

W: 20 kg

SOFA

L: 155 cm; W: 75 cm; H: 65 cm (back); h: 40 cm (seat)

W: 50 kg

Colours : *Black - Grey /*

Beige - Beige /

Black - Yellow /

Beige - Coral /

Beige - Turquoise /

Red - Coral, White, Yellow /

*Monochrome (fabric among PETITE FRITURE
selection of Kvadrat bundles)*

VILLA P.F. Selection – Light grey - Caramel

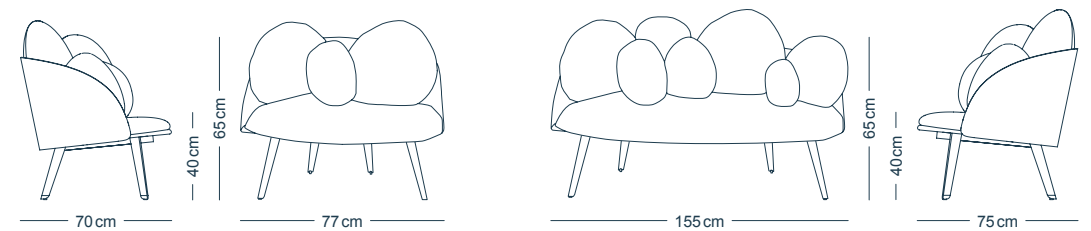

GRID

POOL

DAYBED / SOFAS / ARMCHAIRS / STOOL / COFFEE TABLE



FABRICS SELECTIONS



WOOD VARIETY



Other fabric selection is possible among the following KVADRAT bundles:
PLOT, GALAXY, CANVAS, STEELCUT TRIO 2, CODA 2.

LEATHER COLOURS



Round cushion : Royal blue
Headrest : Beige

Pepper,
light aqua green

Brick
Coral

Dark blue
Mustard

Black
Grey

INDIVIDUAL PIECES

DAYBED



Coated steel, walnut/oak, leather, polyester foam
Fabric covering among PETITE FRITURE selections

L: 187cm; W: 71cm; H: 92cm (back); h: 45cm (seat)
W: 45kg

The fabric for the pictured daybed is one of the
MODULAR P.F. Selection (133)



SOFA WITH 2 ARMRESTS



Coated steel, walnut/oak, leather, polyester foam
Fabric covering among PETITE FRITURE selections

L: 146cm; W: 71cm; H: 86/92cm (back); h: 45cm (seat)
W: 50kg

The fabric for the pictured sofa is one of the
MODULAR P.F. Selection (133)

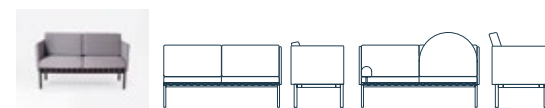

INDIVIDUAL PIECES

ARMCHAIR



Coated steel, walnut/oak, leather, polyester foam
Fabric covering among PETITE FRITURE selections

L: 76cm; W: 71cm; H: 86/92cm (back); h: 45cm (seat)
W: 34kg

The fabric for the pictured armchair is one of the
MODULAR P.F. Selection (133)

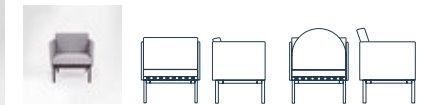

MODULAR ELEMENTS

SOFA



Coated steel, walnut/oak, leather, polyester foam
Fabric covering among PETITE FRITURE selections

L: 140cm; W: 71cm; H: 86/92cm (back); h: 45cm (seat)
W: 40kg

The fabric for the pictured sofa is one of the
MODULAR P.F. Selection (133)

Standards :



SOFA WITH 1 ARMREST (RIGHT OR LEFT)



Coated steel, walnut/oak, leather, polyester foam
Fabric covering among PETITE FRITURE selections

L: 143cm; W: 71cm; H: 86/92cm (back); h: 45cm (seat)
W: 45kg

The fabric for the pictured sofa is one of the
MODULAR P.F. Selection (133)

Standards :



MODULAR ELEMENTS

COFFEE TABLE



Walnut/oak, coated steel

L: 68cm; W: 68cm; H: 33cm
W: 21 kg

Standards :



STOOL



Coated steel, walnut/oak, leather, polyester foam

L: 68cm; W: 68cm; H: 45cm
W: 17 kg



ARMCHAIR WITHOUT ARMREST



Coated steel, walnut/oak, leather, polyester foam
Fabric covering among PETITE FRITURE selections

L: 68cm; W: 71cm; H: 86/92cm (back); h: 45cm (seat)
W: 24 kg

The fabric for the pictured armchair is one of the MODULAR P.F. Selection (133)

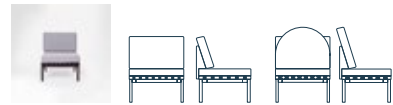

CORNER ARMCHAIR (RIGHT OR LEFT)



Coated steel, walnut/oak, leather, polyester foam
Fabric covering among PETITE FRITURE selections

L: 71cm; W: 71cm; H: 86/92cm (back); h: 45cm (seat)
W: 29 kg

The fabric for the pictured armchair is one of the MODULAR P.F. Selection (133)

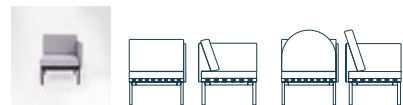

CONFIGURATION SUGGESTIONS

STRAIGHT FIXING SET & CORNER FIXING SET ARE AVAILABLE UPON REQUEST

3 SEATS SOFA WITHOUT ARMREST

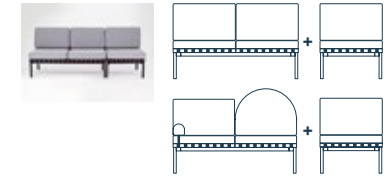

3 SEATS SOFA WITH ARMREST (RIGHT OR LEFT)

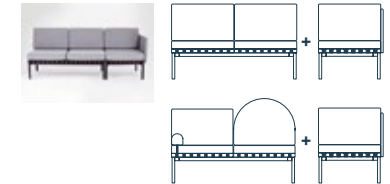

4 SEATS SOFA WITH ARMRESTS

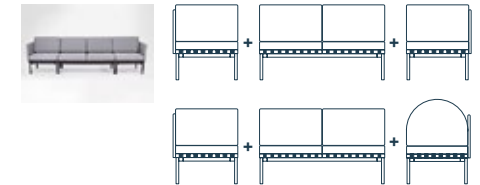

CORNER SOFA (RIGHT OR LEFT)

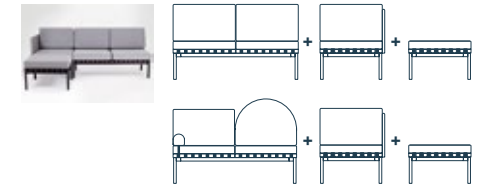

HOFF

MORTEN & JONAS

MODULAR STOOLS AND ARMCHAIRS



FABRICS SELECTIONS



LEG COLOURS



Other fabric selection is possible among the following KVADRAT bundles:
PLOT, GALAXY, CANVAS, STEELCUT TRIO 2, CODA 2.

Frame in steel and wood, cushions in polyurethan foam, fabric covering among *PETITE FRITURE* selections. Each modular element is supplied with a set of 2 legs attachment strings.

STOOLS



SMALL / L: 50 cm; W: 68 cm; H: 40 cm
W: 14 kg

The fabric for the pictured stool is one of the
VILLA P.F. Selection (GALAXY 108)

Standards :

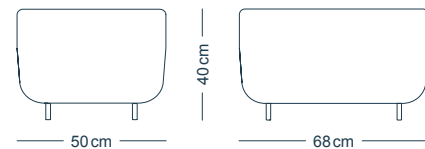

MEDIUM / L: 68 cm; W: 68 cm; H: 40 cm
W: 14.5 kg

The fabric for the pictured stool is one of the
VILLA P.F. Selection (PLOT 443)

Standards :

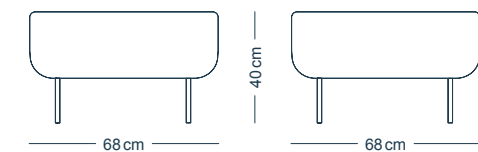

ARMCHAIRS

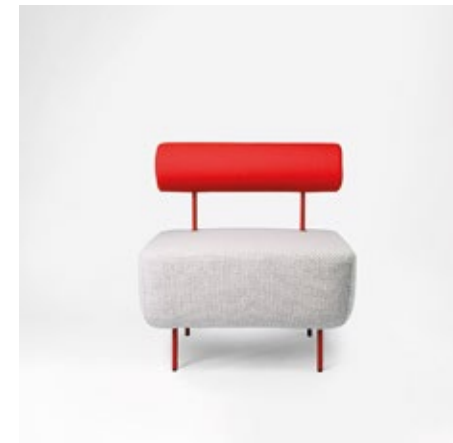

MEDIUM / L: 68 cm; W: 68 cm;
H: 72.5 cm (back); h: 40 cm (seat)
W: 17 kg

The fabric for the pictured armchair is one of the
VILLA P.F. Selection (seat: CODA 2 - 232 / back: PLOT 553)

Standards :

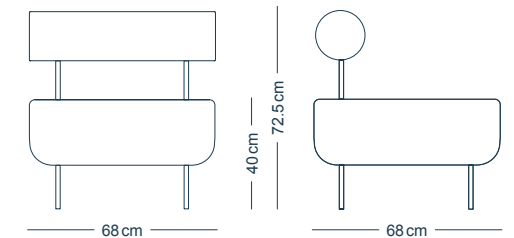

LARGE / L: 99.5 cm; W: 68 cm;
H: 72.5 cm (back); h: 40 cm (seat)
W: 18 kg

The fabric for the pictured armchair is one of the
VILLA P.F. Selection (seat: PLOT 443 / back: GALAXY 108)

Standards :

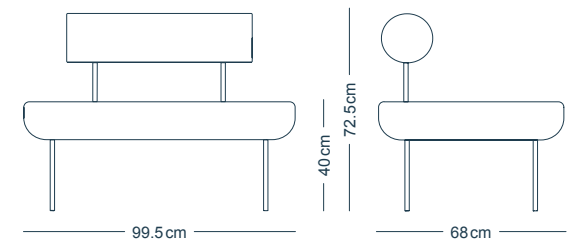

See p. 36-37



MASK
FEDERICO FLORIANI
WALL MIRRORS

Tinted lacquered mirror

RHOMBUS
W: 60 cm; H: 120 cm
W: 5 kg
Colour : Coral

HEXAGON
W: 65 cm; H: 75 cm
W: 5 kg
Colour : Lead

OVAL
W: 60 cm; H: 120 cm
W: 9 kg
Colour : Bronze

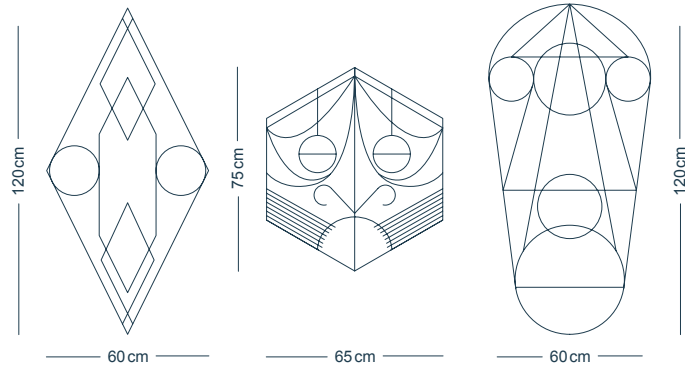

See p.21

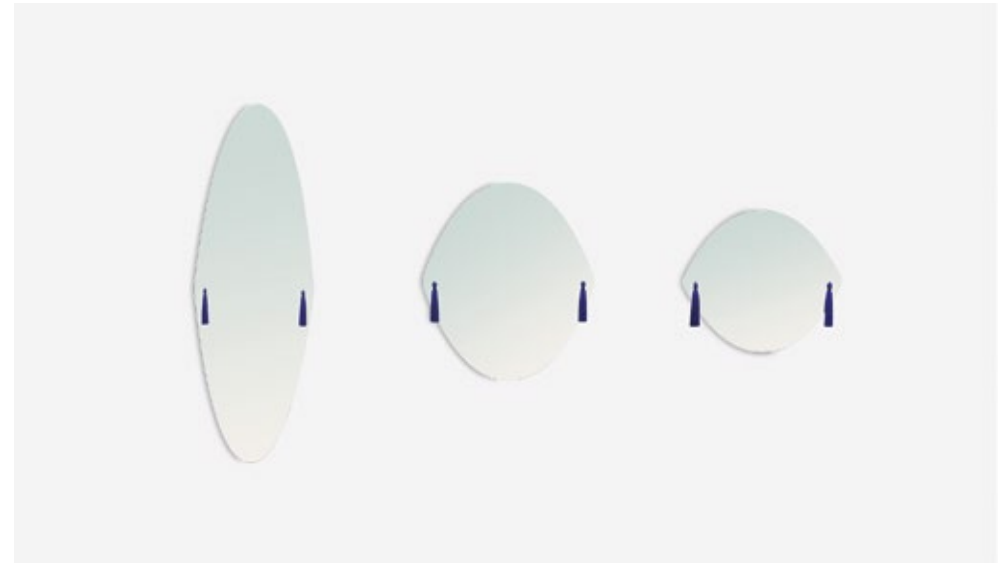

PANACHE
CONSTANCE GUISSSET
WALL MIRRORS



Lacquered mirror

SMALL
W: 42 cm; H: 37 cm
W: 1 kg

MEDIUM
W: 50 cm; H: 58 cm
W: 2 kg

LARGE
W: 37 cm; H: 112 cm
W: 3 kg

Supplied with an interchangeable tassels kit (duo of 2 tassels available in 3 colors: blue, black, gold)

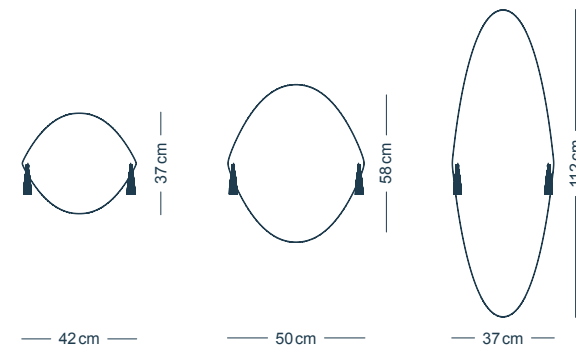

See p. 12

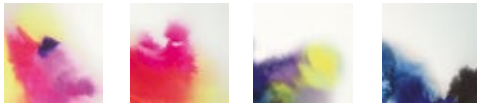

See p. 17



FRANCIS
CONSTANCE GUISET
 WALL MIRRORS

Mirror, aluminium, grained epoxy paint

SMALL / Ø: 45cm; W: 5cm
 W: 3kg

LARGE / Ø: 60cm; H: 5cm
 W: 7kg

Colours : Blue / Pink (one pattern per size)

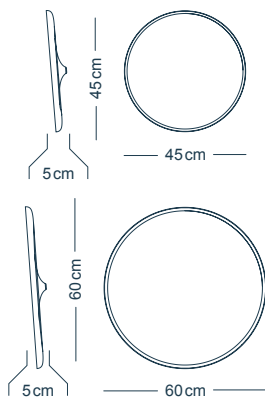

LOOP
AMANDINE CHHOR
 SHELF

Steel, grained epoxy paint

L: 160cm; **W**: 15cm; **H**: 34.5cm
 W: 4.5kg

Colours : Yellow / White

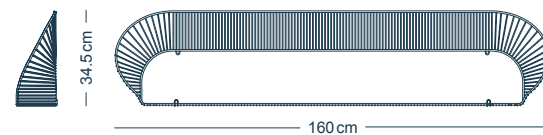

See p. 43



VERTIGO
CONSTANCE GUISET
 PENDANT LAMPS

Fiberglass, iron, polyurethane

SMALL / Ø: 140cm; H: 15cm
LARGE / Ø: 200cm; H: 17cm
 W: <0.5kg

Colours : Green / Copper / Black /
 White / Light pink / Light Blue

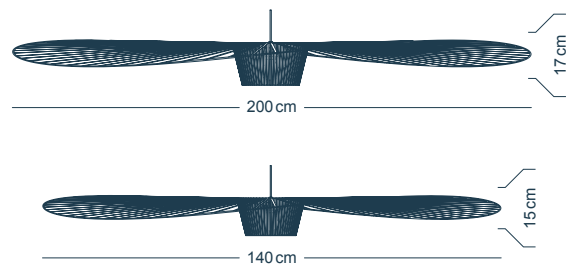

See p. 10



AURA
TOMAS KRAL
 PENDANT LAMPS

Smooth epoxy paint steel, brass brushed and varnished

SMALL / Ø: 33cm; H: 17cm
 W: 0.8kg

LARGE / Ø: 63cm; H: 22.5cm
 W: 1.8kg

Colours : Black-Brass / White-Brass

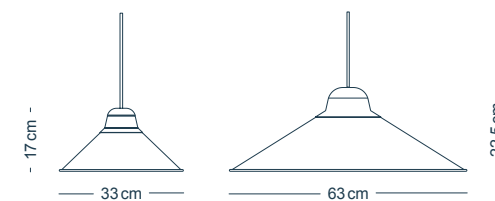

See p. 44 - 45



MÉDITERRANÉA

NOÉ DUCHAUFOUR-LAWRANCE

WALL LAMP / PENDANT LAMPS / TABLE LAMP / FLOOR LAMP

TABLE LAMP

L: 33cm; W: 21cm; H: 44.5cm
W: 1.3kg

Standards :
220-240 V 50-60 Hz
Warm white 2700°K
216lumens

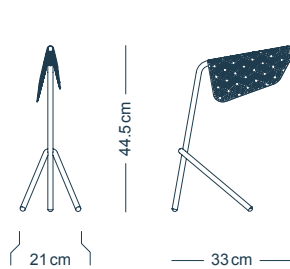

FLOOR LAMP

L: 54cm; W: 34cm; H: 120cm
W: 2kg

Standards :
220-240 V 50-60 Hz
Warm white 2700°K
312lumens



Brushed brass, satin vanish

WALL LAMP

L: 34cm; W: 20cm; H: 15cm
W: 1kg

Standards :
220-240 V 50-60 Hz
Warm white 2700°K
324lumens

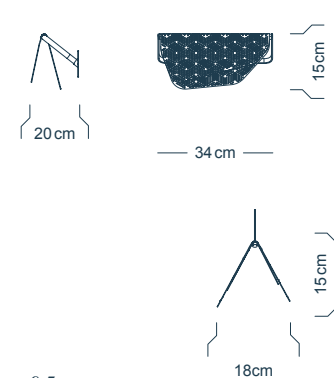

PENDANT LAMPS

SMALL / L: 100.5cm; W: 18cm; H: 15cm
W: 4kg

Standards :
220-240 V 50-60 Hz
Warm white 2700°K
936lumens

LARGE / L: 160cm; W: 18cm; H: 15cm
W: 6kg

Standards :
220-240 V 50-60 Hz
Warm white 2700°K
1620lumens

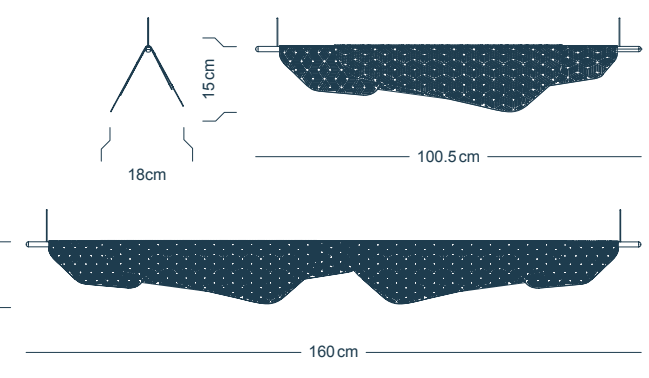

See p.29



SO-SAGE

SAM BARON

PENDANT LAMPS

Borosilicate glass, brass graphite finish, steel

DIOT /
 Ø: 4.2cm; H: 15cm
 W: 0.5kg

CERVELAS /
 Ø: 8cm; H: 20cm
 W: 0.7kg

STRASBOURG /
 Ø: 3.6cm; H: 25cm
 W: 0.6kg

MORTEAU /
 Ø: 7cm; H: 35cm
 W: 0.9kg

GENDARME /
 Ø: 3.6cm; H: 40cm
 W: 0.6kg

TOULOUSE /
 Ø: 4.2cm; H: 30cm
 W: 0.6kg

Ceiling Ø: 15 cm

Cable length L: 175 cm

SET of 3 - n°1 /
CERVELAS + TOULOUSE + STRASBOURG (cut version)
 W: 1kg

SET of 3 - n°2 /
STRASBOURG + MORTEAU + CERVELAS (cut version)
 W: 1kg

SET of 3 - n°3 /
DIOT + GENDARME + CERVELAS (cut version)
 W: 1kg

Ceiling Ø: 15 cm

SET of 5 /
DIOT + MORTEAU + TOULOUSE + STRASBOURG (cut version) + CERVELAS (cut version)

Ceiling Ø: 18cm
 W: 1.7kg

Line of 6 /
DIOT + STRASBOURG (cut version) + CERVELAS + MORTEAU + TOULOUSE + CERVELAS (cut version)
 Ceiling L: 100cm
 W: 2.8kg

Cable length L: 175 cm

Standards :
 220-240V 50-60Hz

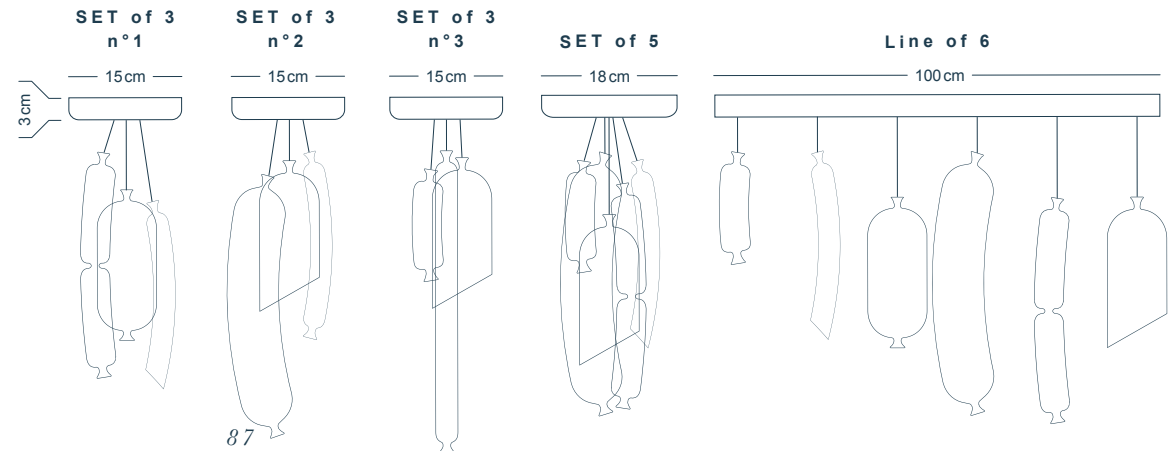
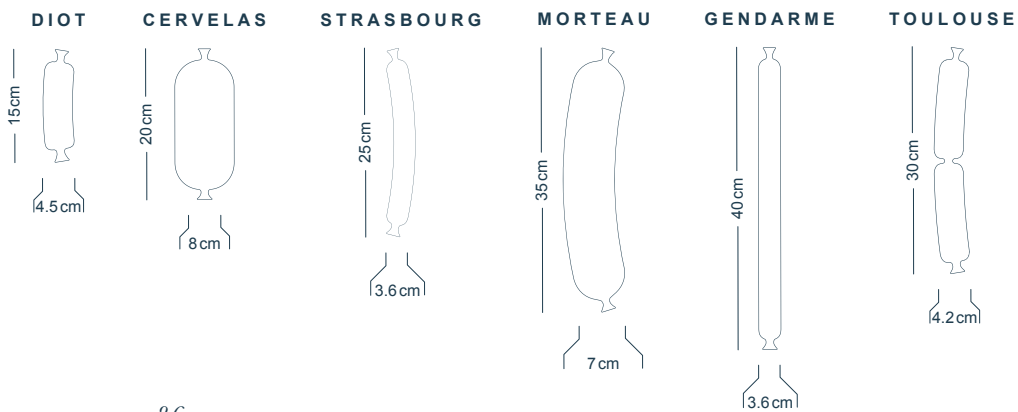

See p.28



LANTERNA
SAM BARON
PENDANT LAMPS

Lacquered steel, cotton, PVC

SMALL / Ø: 22cm; H: 42cm
W: 0.4kg

MEDIUM / Ø: 47cm; H: 60cm
W: 0.8kg

LARGE / Ø: 75cm; H: 50cm
W: 1.2kg

Colours : Black - Gold / White - Gold

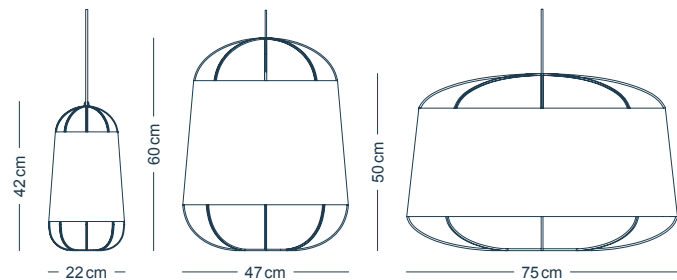

See p.40



MOIRE
MARC SARRAZIN
ADAPTABLE LAMPS

Polyester, lacquered copper, grained epoxy paint

SMALL / Ø: 35cm; H: 35cm
W: 0.7kg

LARGE / Ø: 50cm; H: 50cm
W: 0.8kg



Colours : Black / White

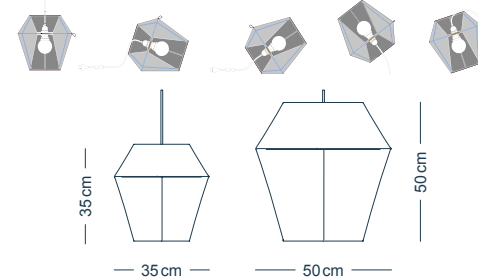

See p.35



CHERRY
DANIEL • EMMA
PENDANT LAMPS

Aluminium, grained epoxy paint, mirror finish steel, plexiglass

SMALL / Ø: 16cm; H: 37.5cm
W: 0.5kg

LARGE / Ø: 50cm; H: 37.5cm
W: 2kg



Colours : Black - Rainbow / White - Gold

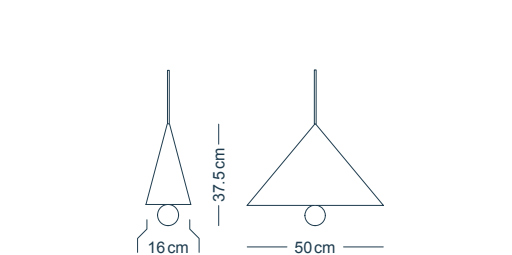

See p. 16



See p. 49

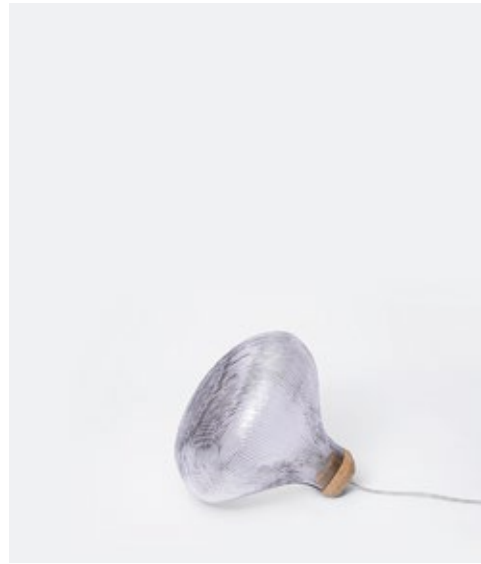

CAST

studio vit
PENDANT LAMP / FLOOR LAMP

Mass tinted concrete, borosilicate glass

PENDANT LAMP / Ø: 20.5 cm; H: 23 cm
W: 1.5 kg

TABLE LAMP / Ø: 16 cm; H: 27 cm
W: 2.9 kg

Standards :
220-240 V 50-60 Hz

Colour : Grey

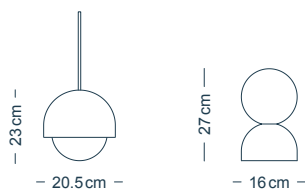

TIDELIGHT

PIERRE FAVRESSE
TABLE / FLOOR LAMP

Blown glass, cork

Ø: 30 cm; L: 26.5 cm; H: 26.5 cm
W: 2 kg

Standards :
220-240 V 50-60 Hz

Colours : Smoked / Transparent

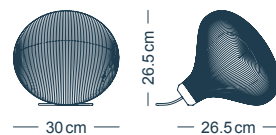

See p. 52-53



GRILLO

ELISE FOUIN
WALL LAMPS

Coated steel, grained epoxy paint, textile cable

SMALL / Ø: 23 cm; W: 10 cm
W: 0.3 kg

LARGE / Ø: 36 cm; W: 10 cm
W: 0.6 kg

Standards :
220-240 V 50-60 Hz

Colours : White - Fluo Pink
White - Teal Green
White - Fluo Yellow
White - White

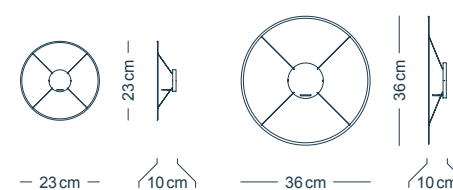

WALL LAMPS WITH CABLE (SWITCH AND PLUG)

Coated steel, grained epoxy paint, textile cable

SMALL / Ø: 23 cm; W: 10 cm
W: 0.3 kg

LARGE / Ø: 36 cm; W: 10 cm
W: 0.6 kg

CABLE / L: 300 cm

Standards :
220-240 V 50-60 Hz

Colours : White - Teal Green
White - Fluo Yellow
White - Fluo Pink
White - White

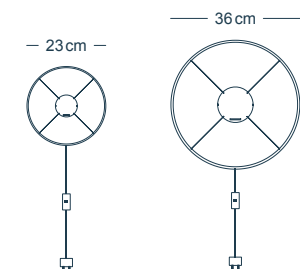

See p. 38



BUBBLE
VAULOT & DYÈVRE
COAT PEGS

Blown glass, steel

SMALL / L: 9.5cm; W: 9.5cm; H: 7.5cm
W: 0.25kg

LARGE / L: 13cm; W: 15cm; H: 13cm
W: 0.35kg

Colours : Blue / Coral / Grey / Yellow

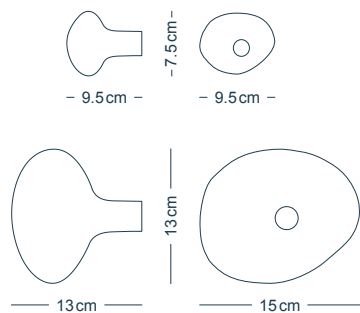

See p. 55



TUBERCULE
SCMP DESIGN OFFICE
COAT PEGS (SET OF 2)

Mass tinted concrete

Model 1 / L: 5cm; W: 8.5cm; P: 6cm (+ screw 3cm)
W: 0.25kg

Model 2 / L: 5cm; W: 9cm; P: 6cm (+ screw 3cm)
W: 0.25kg

Standards : 

Colours : Blue / Grey

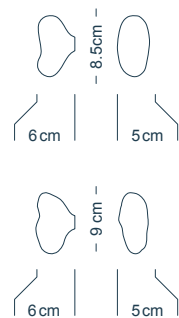

See p. 20

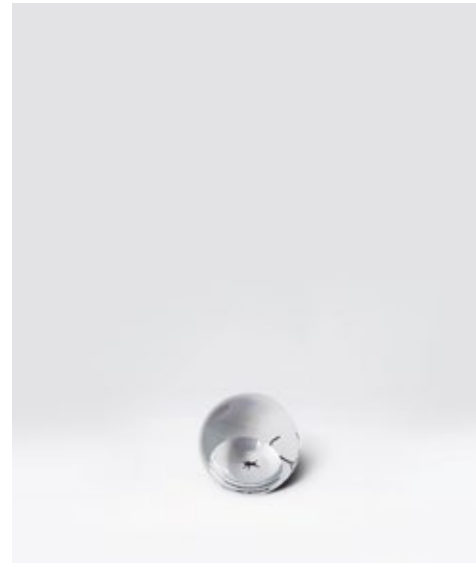

ANT
SAM BARON
PAPERWEIGHT

Glass

Ø: 8cm
W: 0.6kg



See p. 18



ÉTOILE
CLAESSON KOIVISTO RUNE
CHOPBOARD

Oak

L: 36cm; W: 36cm; H: 2cm
W: 1.3kg

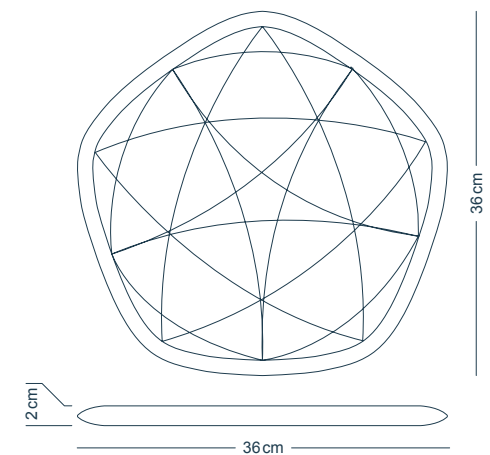

See p.29

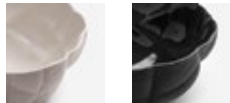

SUCCESSION

FÄRG & BLANCHE x PETITE FRITURE & REVOL
TABLEWARE

Alimentary porcelain

ESPRESSO CUP / Ø: 6.2cm; H: 6.3cm
W: 0.1kg

MUG / Ø: 10cm; H: 9cm
W: 0.2kg

PITCHER / Ø: 12cm; H: 17.5cm
W: 0.75kg

BOWL / Ø: 17cm; H: 5.6cm
W: 0.5kg

Colours : *Black / White*

SERVING BOWL / Ø: 28cm; H: 10cm
W: 1.6kg

PLATE / Ø: 26cm; H: 2.8cm
W: 0.7kg

DESSERT PLATE / Ø: 21cm; H: 2.2cm
W: 0.4kg

SOUP PLATE / Ø: 23cm; H: 3.8cm
W: 0.6kg

Standards : 

 (all the references except the serving bowl and the pitcher)

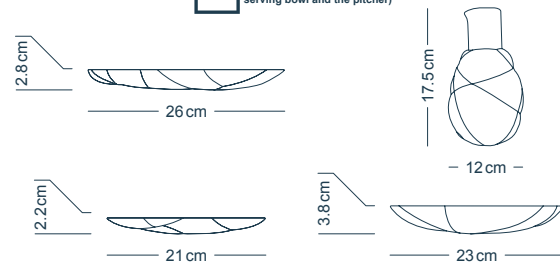
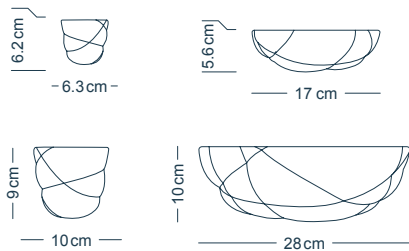

See p.54

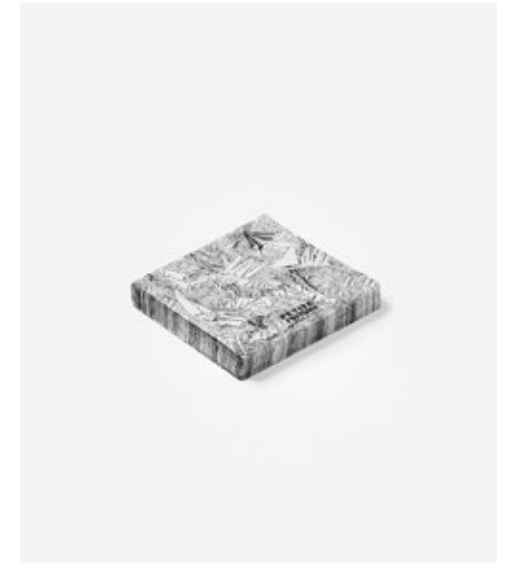

BRILLE

PETITE FRITURE
BOWLS

Ceramic

SMALL / Ø: 10cm; H: 6.5cm; 0.2L
LARGE / Ø: 15cm; H: 9.5cm; 0.5L

Standards : 

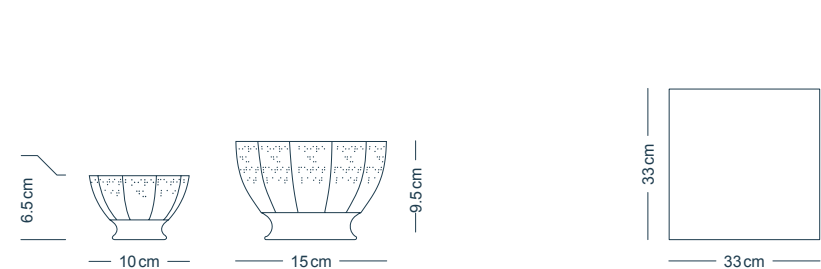

JUNGLE

TIPHAINE DE BODMAN
SET OF 20 PAPER NAPKINS

Cellulose

L: 33cm; H: 33cm

Colour : *Black*

See p. 39

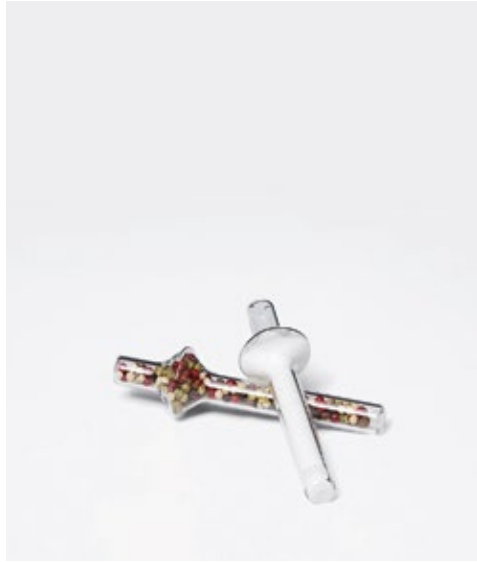

BAMBOU

CÉLINE FRÉBAULT
SALT & PEPPER SHAKERS (THE PAIR)

Borosilicate glass

Ø: 3.5cm; Ø: 1cm; L: 13cm
W: 0.03kg (each)

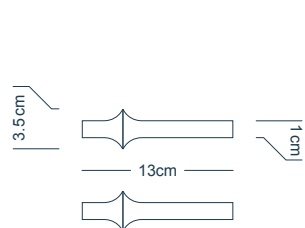

See p. 42



OBJETS 2822

GAËLLE GABILLET & STÉPHANE VILLARD
DOMESTIC DECANTERS

Black glass

SMALL / Ø: 8cm; H: 9cm
W: 0.25kg
0,25 L

LARGE / Ø: 8cm; H: 17.5cm
W: 0.5kg
0,5 L

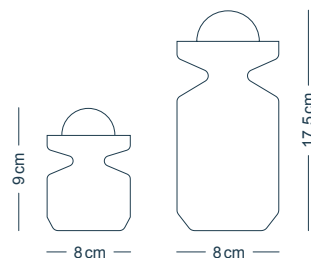

See p. 41



WILD CAR

PIERRE FAVRESSE
MONEYBOX

Porcelain, cork

L: 13.5cm; W: 7.5cm; H: 8.5cm
W: 0.3kg



See p. 23



WILD THINGS

PIERRE FAVRESSE
CONTAINERS

Ceramic

SMALL / Ø: 10cm; H: 13cm
W: 0.6kg

LARGE / Ø: 10cm; H: 16cm
W: 0.7kg

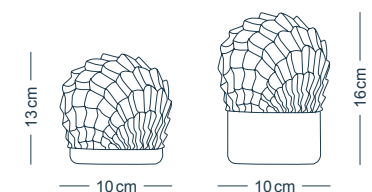

See p. 30

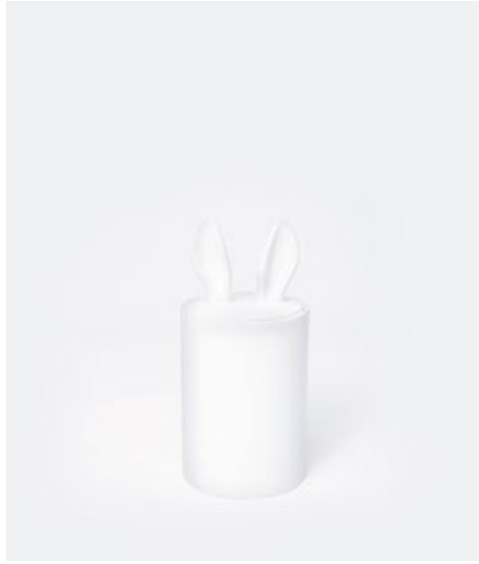

CURIOSITY
SAM BARON
CONTAINER

Ceramic

Ø: 12.5 cm; H: 28 cm
W: 1 kg

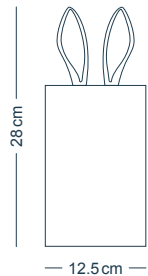

See p. 31



CURIOSITY
SAM BARON
DECORATIVE PLATE

Ceramic

Ø: 27.5 cm
W: >1 kg

Attachment provided.

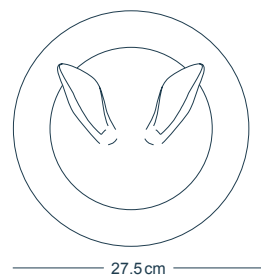

See p. 22



GRANDISSANT
JEAN-CHARLES AMEY
CANDLE HOLDERS

Concrete

9 modules
Base / L: 51 cm; W: 27.5 cm; H: 5 cm
Module / L: 12 cm; H: 14.5 cm
W: 6 kg

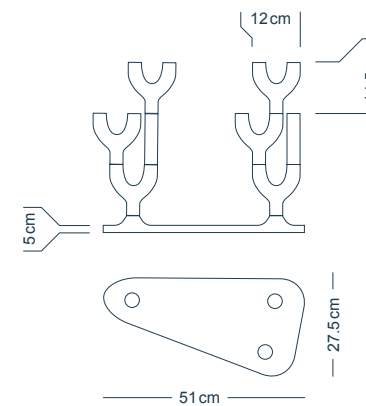

See p. 22



3 modules
Base / Ø: 21 cm; H: 5 cm
Module / L: 12 cm; H: 14 cm
W: 3 kg

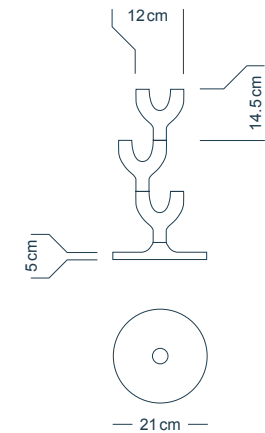

See p. 11



See p. 11



NARCISO
ECAL/GIORGIA ZANELATO
VASES

Glass, mirror polish stainless steel

PIATTO (LOW) / Ø: 30 cm; H: 12 cm
W: 3 kg



CERCHIO (HIGH) / Ø: 31 cm; Ø: 11 cm; H: 60 cm
W: 5 kg

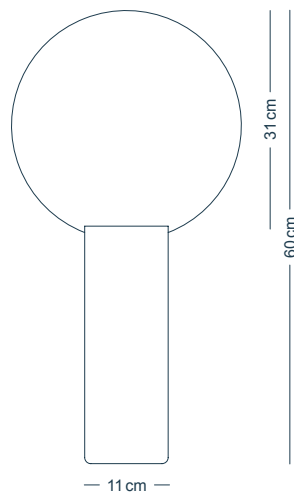

See p. 48



CANDLE TORCH
ANDREAS ENGESVIK
CANDLE HOLDERS

Ceramic

SMALL / L: 7 cm; W: 9 cm; H: 11 cm
W: 0.25 kg

LARGE / L: 9 cm; W: 10 cm; H: 26.5 cm
W: 0.35 kg

Colours : Grey / Coral / White

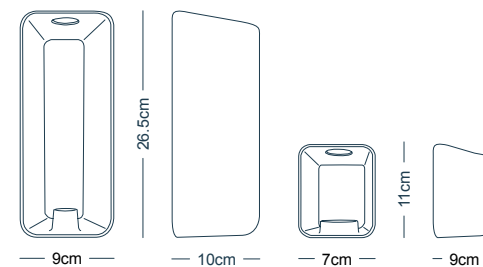

See p. 13



MINERA
STUDIO NOCC
CARAFE

Glass

L: 11 cm; W: 7.5 cm; H: 23 cm
W: 0.75 kg
1L

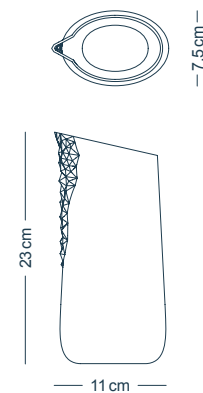

See p. 45

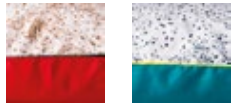

DOTS
SHELLEY STEER
CUSHIONS



Velvet, polyester, cotton

SQUARE / L: 50cm; W: 50cm; H: 17cm
W: 0.9kg

Colours : Front side: Copper / Back side: Red /
Piping: Multicolor

Velvet, cotton, lurex

RECTANGULAR / L: 60cm; W: 40cm; H: 15cm
W: 1kg

Colours : Front side : Black / Back side: Green /
Piping: Yellow

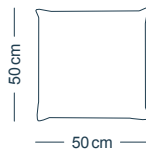

See p. 45

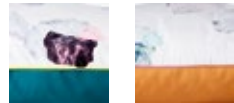

MINERALS
SHELLEY STEER
CUSHIONS



Satin cotton, cotton, polyester

SQUARE / L: 50cm; W: 50cm; H: 17cm
W: 0.9kg

Colours : Front side: Black-Pink /
Back side: Green / Piping: Yellow

Satin cotton, cotton, polyester

RECTANGULAR / L: 60cm; W: 40cm; H: 15cm
W: 1kg

Colours : Front side: Turquoise-Coral /
Back side: Bronze / Piping: Pink

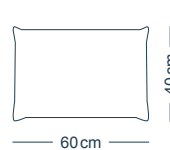

See p. 45

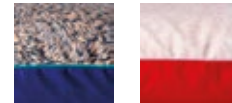

VOLUTES
TIPHAINE DE BODMAN
CUSHIONS



Velvet, cotton, polyester

SQUARE / L: 50cm; W: 50cm; H: 17cm
W: 0.9kg

Colours : Front side: Black / Back side: Blue /
Piping: Green

Velvet, cotton, polyester

RECTANGULAR / L: 60cm; W: 40cm; H: 15cm
W: 1kg

Colours : Front side: Pink / Back side: Red /
Piping: Pink

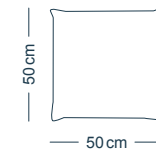

See p. 45



JUNGLE
TIPHAINE DE BODMAN
CUSHIONS



Satin cotton, polyester, cotton, lurex

SQUARE / L: 50cm; W: 50cm; H: 17cm
W: 0.9kg

Colours : Front side: White on Black /
Back side: Bronze / Piping: Green

Satin cotton, cotton, polyester

RECTANGULAR / L: 60cm; W: 40cm; H: 15cm
W: 1kg

Colours : Front side: Copper / Back side: Blue /
Piping: Multicolor

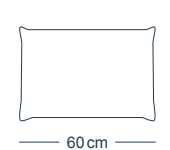

See p.44

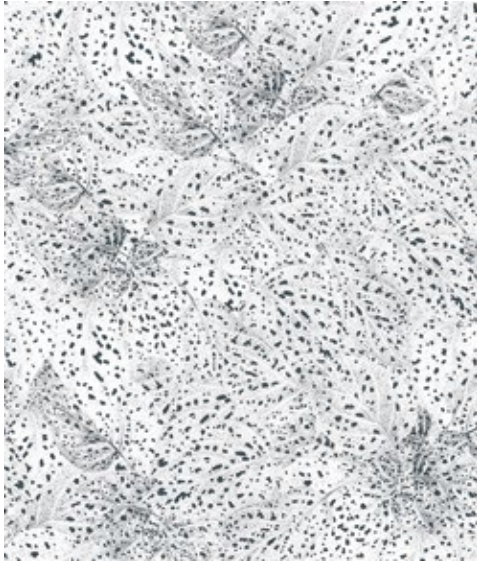

DOTS
SHELLEY STEER
WALLPAPERS



MINERALS
SHELLEY STEER
WALLPAPERS



Un-woven paper with half-drop match

L: 0.52m; H: 10m
W: 1kg

Colours : Copper / White on black / Black



See p.45

See p.21

See p.24

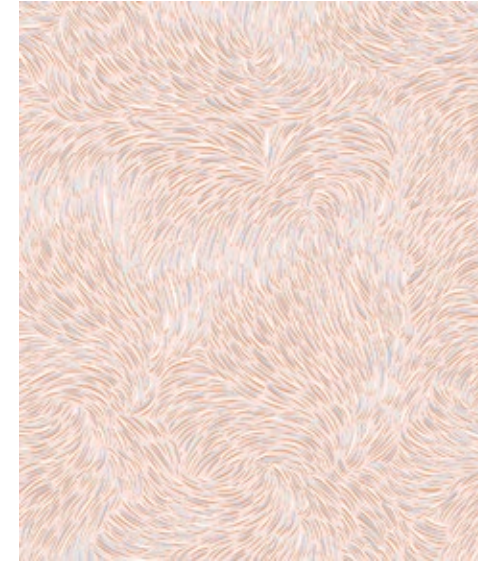

VOLUTES
TIPHAINE DE BODMAN
WALLPAPERS



JUNGLE
TIPHAINE DE BODMAN
WALLPAPERS



Un-woven paper with straight across match

L: 0.70m; H: 10m
W: 1kg

Colours : Green / Pink / Black

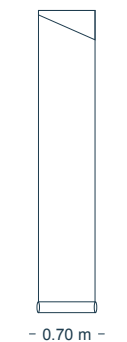

Un-woven paper with half-drop match

L: 0.70m; H: 10m
W: 1kg

Colours : Copper / White on black / Black / Ink

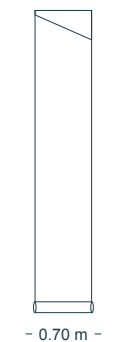

See p.26



VARIATIONS

TIPHAINE DE BODMAN

WALLPAPER

(STRIPE 1 AND 2 SOLD SEPARATELY)

Un-woven paper

L: 48 cm; H: 300 cm

Colours : *Black / Ink*

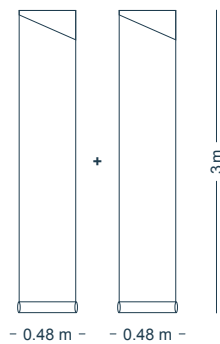

GRAPHIC DESIGN / LAYOUT
PETITE FRITURE

PHOTOGRAPHY
Ola Rindal (*interior*)
Léa Baert (*stylism*)

OTHER PHOTOGRAPHIES
(*p.16 - 21 - 29 - 44 - 45 - 55*)
PETITE FRITURE

PRINTING
Kappadue Arti Grafiche

PETITE FRITURE
*83 boulevard Richard Lenoir,
75011 — Paris
France*

T: +33 (0)1 44 54 13 95
F: +33 (0)1 44 54 02 19

S A L E S
sales@petitefriture.com

petitefriture.com

